

# DATA SHEET

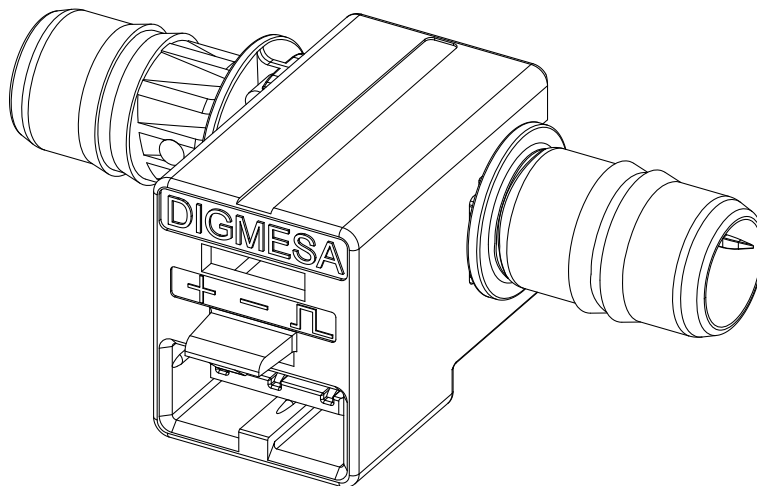

***DIGMESA***<sup>®</sup>  
SWITZERLAND

---

Nano DM60 with POM turbine  
Part number: 93N-6411-1100x

Digmesa AG, Keltenstrasse 31, CH-2563 Ipsach / Switzerland

Phone +41 (32) 332 77 77, Fax +41 (32) 332 77 88

[www.digmesa.com](http://www.digmesa.com)

Version 01 Nano #93N-6411-1100x GB Page 1-5

# General Description

The Nano Flow Sensor is a general-purpose device that has been specially designed for coffee machines that use vibratory pumps. The device is installed between the water tank and the vibratory pump (on the suction side). This way measuring errors that arise during pulsating water flow caused by vibration pumps are minimized.

**Specific applications: Doubled isolation (liquid/electronics) according to the standard IEC/EN 60335-1: 2001/2002 + A1: 04 + A2: 06 + A11: 04 + A12: 06.**

## Approvals / Standards

EN55014-1:00+A1:01+A2:02, EN61000-6-3:01+A11:04, IEC61000-6-3:06(ed.2.0), EN61000-3-2:06, IEC61000-3-2:05(ed.3.0), EN61000-3-3:95+A1:01+A2:05, IEC61000-3-3:94+A1:01+A2:05(Cons.ed 1.2), EN55014-2:97+A1:01, EN61000-6-1:01, IEC61000-6-1:05(ed.2), LFGB (EU 1935 /2004, EU10/2011)



## Materials (wetted)

Housing: PP  
 Bearing pin: PP  
 Nozzle: PP Ø 1.1 mm  
 Turbine: POM  
 Magnete: Ceramic Sr Fe O

## Technical data:

Linear range: from 0.05 - 0.40 l/min  
 Durability: min. 3000 liters at 0.4 l/min  
 Resolution: 49'162 pulses/liter  
 Pressure loss: 0.31 bar (4.49 psi) sucking at 0.40 l/min  
 Measuring accuracy: +/- 2.0% \*  
 Temperature range: +0°C to +65°C  
 32°F to 149°F  
 Pressure range: -1 bar to 5 bar at 20°C  
 -14.5 psi to 72.5 psi /68°F  
 Attention: >0.5 bar/7.25 psi pressure secure hose!  
 Mounting position: freely selectable  
 Nozzle size: Ø 1.1 mm

## Electrical connection ratings:

Power supply: +3.0 to +20 VDC  
 Consumption: <8 mA  
 Signal connection: Open collector NPN  
 Signal voltage: 0 VDC GND (saturation <0.7 V)  
 Signal load: max. 20 mA  
 Leakage current: max. 10 µA  
 Connections: Pancon Hallcon plug (contact cycles max. 5x)  
 Signal: Square-wave output  
 Duty Cycle: ~50%



Drying and/or operating with compressed air destroys the flow sensor!

\* Accuracy in the linear range for individually calibrated equipment

## Dimensions in mm:

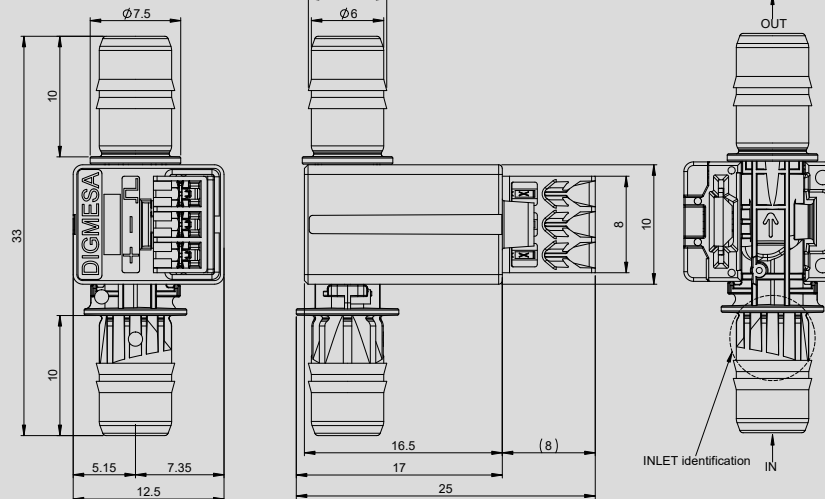

## Option:

Flow Sensor with Pancon Hallcon plug without cable  
 item number: 93N-6411-11001

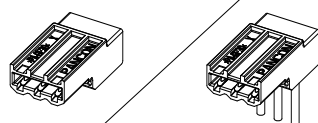

Flow Sensor with Pancon Hallcon plug with cable, length 250mm  
 item number: 93N-6411-11002

We reserve the right to make modifications in the interests of technical progress.

## RESISTANCE

Special regulations which must be complied with by the flow sensor manufacturer apply to each country, e.g. CE, NSF, FDA and SK. The various media flowing through the flow sensor differ from application to application. You are advised to enquire with the medium manufacturer as to whether the entire installation and the flow sensor are resistant to the medium itself (see material)!

## ELECTRONIC

DIGMESA electronic circuitry is always designed for operation with DIGMESA flow sensors. Please note the following if connecting to other electronic circuitry:

- The flow sensor does not supply an output voltage but switches the signal terminal to 0 V ground (actuated) or leaves it open (non-actuated)
- There must be a pull-up resistor between power supply + and signal depending on electronic circuitry!

Version 01 Nano #93N-6411-1100x GB Page 2-5

# Interface Connection: Examples Open Collector

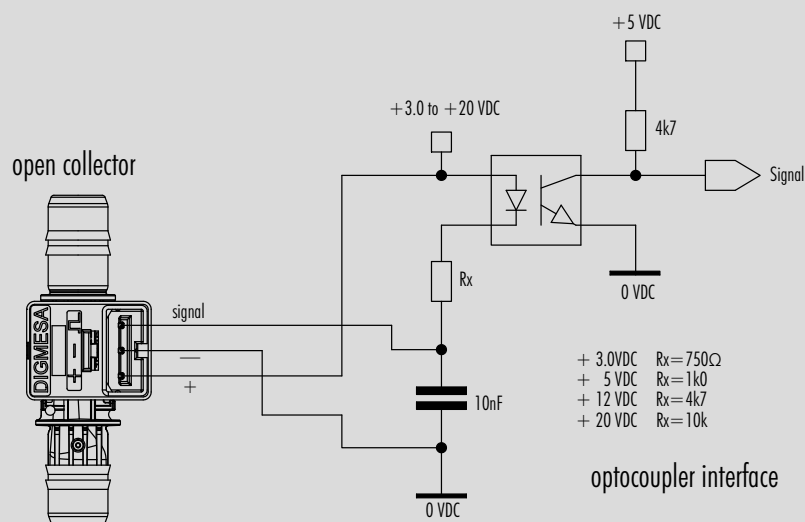
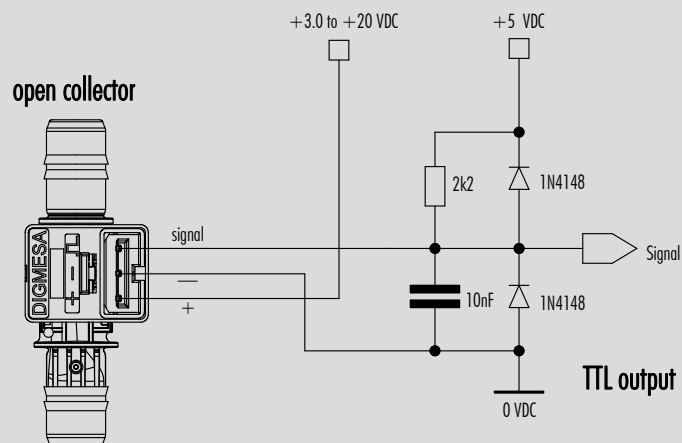
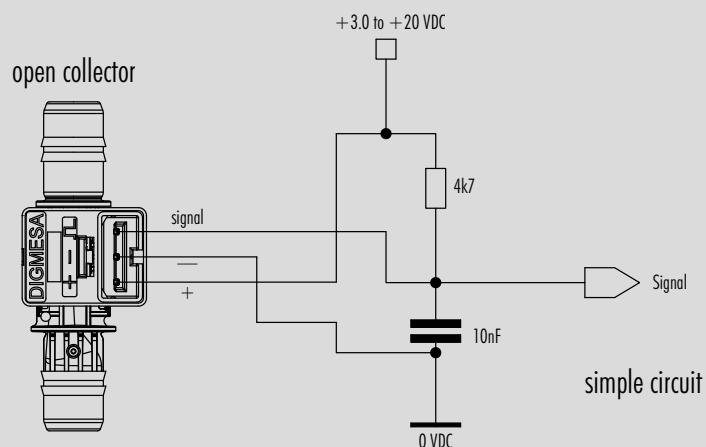

# Application example for household coffee machines

Recommended tubing	
Material	Silicon
Dimensions	Ø5.5mm x 2.0mm
Hardness	50 Shore A
Tube length between flow sensor and pump	> 14 cm

Attention: > 0.5 bar/7.25 psi secure hose!

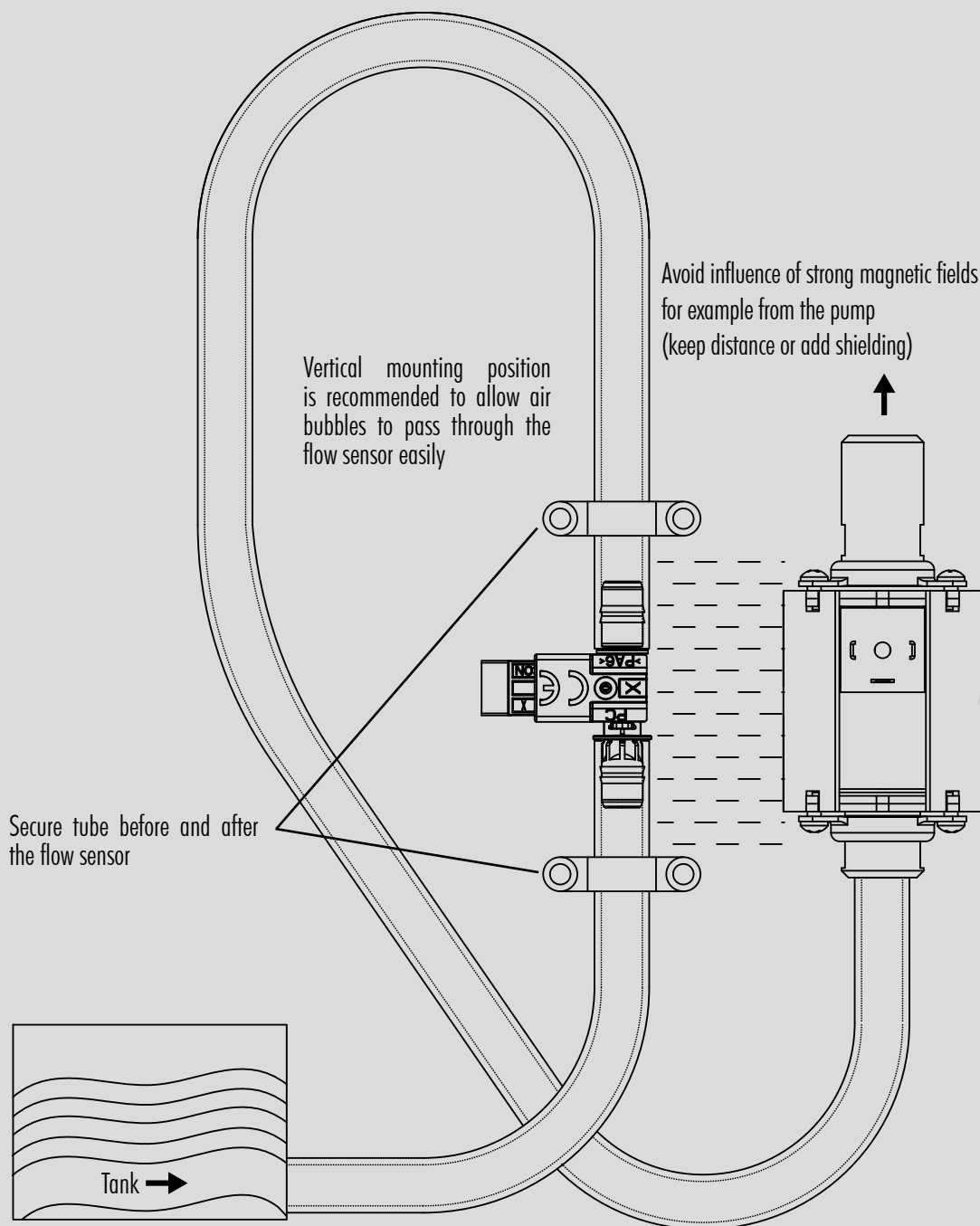

DIGMESA

# Measurement Curve Nano

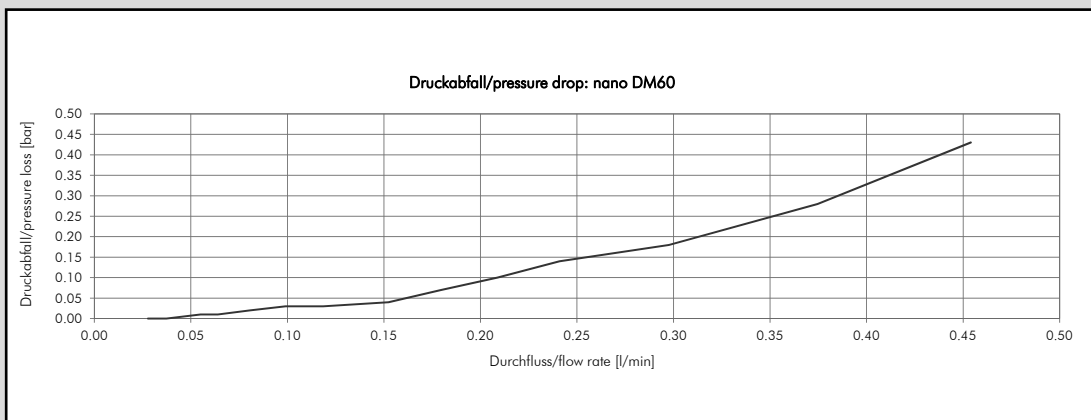
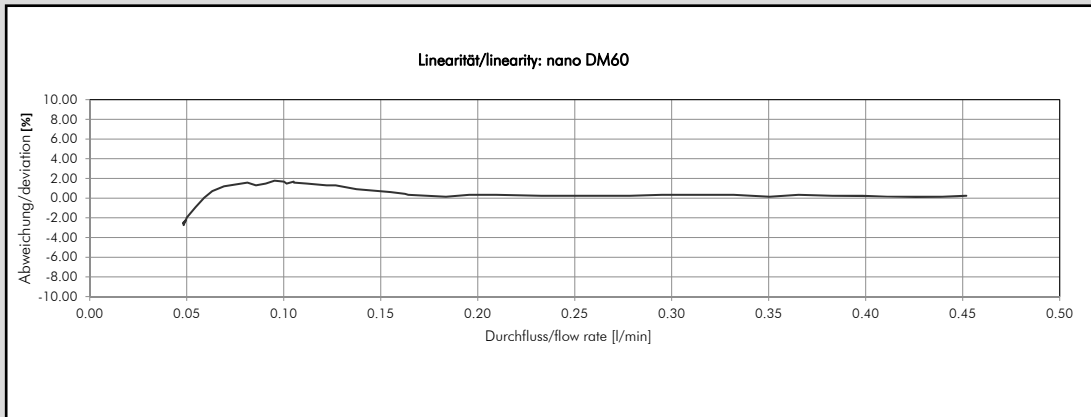

Test Settings: Medium: Water / Pressure: 2.0 bar

Nozzle size	Pulses/Litres	ml/pulse	min. flow rate [l/min]	max. flow rate [l/min]	Pulse frequency [Hz] min/max
Ø 1.1 mm	49'162	0.02	0.05	0.40	40 / 327

## MEASUREMENT TIPS

- Ensure that there is no fast-pulsatory movement of the media
- Ensure that there are no reverse pressure surges
- Ensure that there is no air in the system
- Keep the pressure loss as small as possible
- Pay attention to the mounting position of the flow sensor
- Min/max flow should be in the linear range of the selected flow sensor
- Clean the system at appropriate intervals
- Avoid electrical voltage spikes
- Incorrect wiring of power supply +, signal and ground will destroy the flow sensor
- Do not load electrical contacts mechanically
- Avoid moisture on the electrical contacts
- Avoid stray pick-up via the cable (Do not lay cables in parallel with high current loads)
- > 0.5bar/7.25 psi pressure secure hose!

**The values specified must be considered as approximate values.**

**The number of pulses per litre may differ depending on medium and installation.**

**We recommend to calibrate the number of pulses per litre in line with the complete installation.**